

Operating Manual

XMD01 DENT PULLER

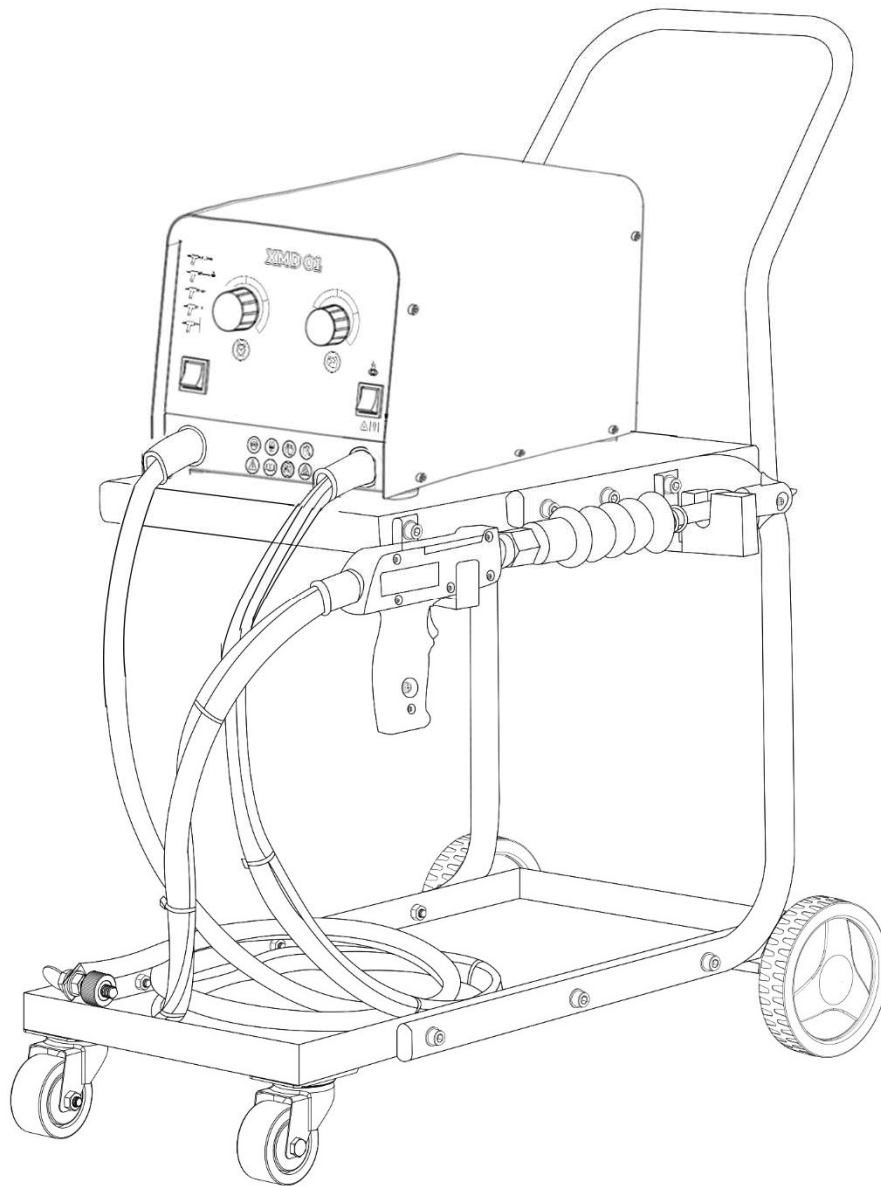

INSTRUCTION: CAREFULLY READ THIS MANUAL BEFORE INSTALLING AND OPERATING THE MACHINE.

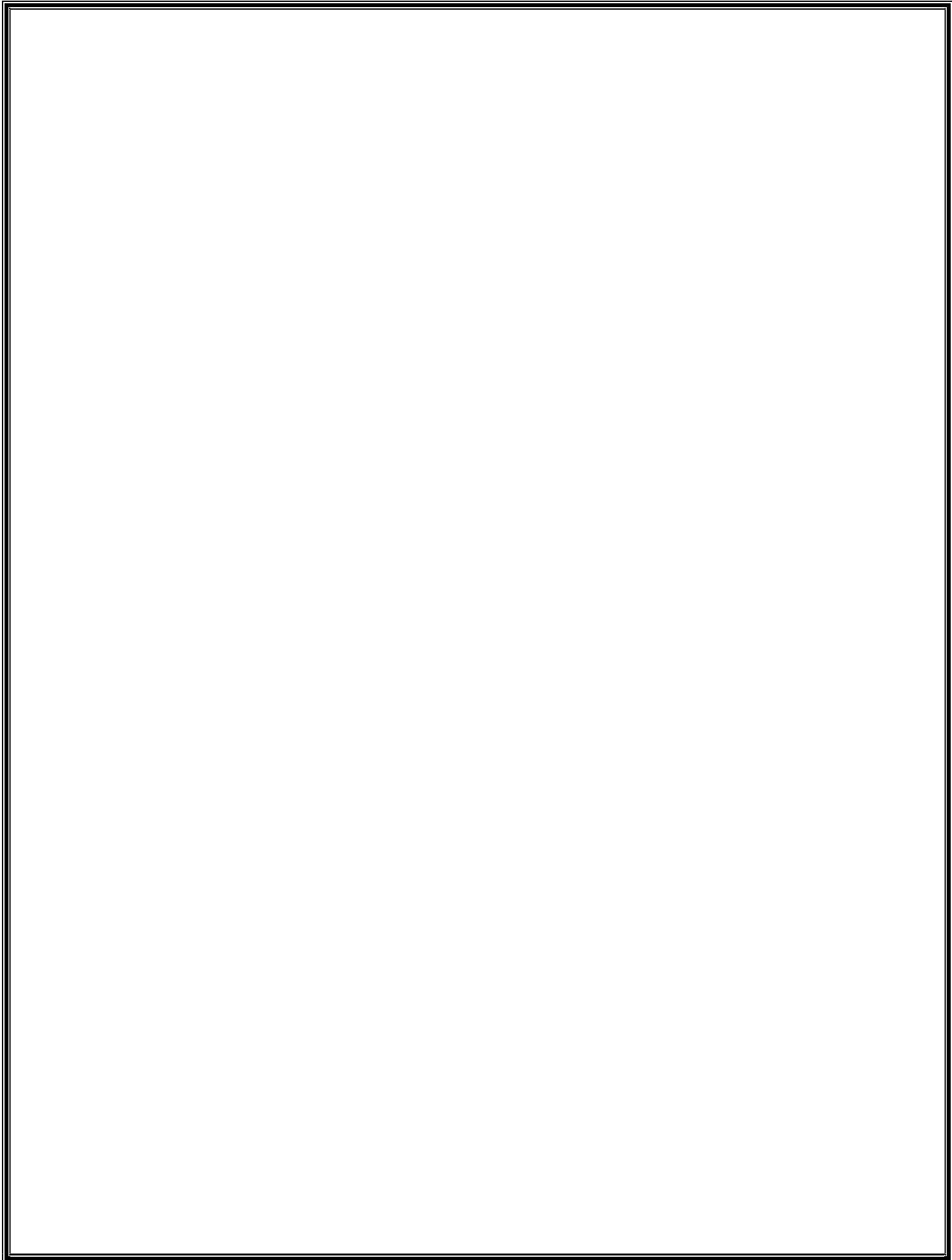

Contents

1	Introduction	Page 4
2	Safety Precautions	Page 4
3	Technical Data	Page 6
4	Electrical Installation	Page 6
5	Ideal Working Conditions	Page 7
6	Control Panel	Page 8
7	Description of Working Cycle	Page 9
8	Use of Tools	Page 9
9	Parts List	Page 14
10	Wiring Diagram	Page 16
11	Maintenance and Service	Page 17
12	Accessories and Scope of Delivery	Page 18
13	Warranty Claiming	Page 19
14	Test Report	Page 21

1. Introduction

This manual is addressed to the person responsible in charge who must release it to the personnel in charge of **DENT PULLER** installation, use and maintenance. He/she must check that the information is given in this manual and the enclosed documents have been read and understood. The manual must be stored in a well-known place, easy to reach, and must be looked up each time when any doubts should arise.

The **DENT PULLER** described in this manual are designed solely for professional use on factory sites not directly connected to high voltage mains intended for domestic applications. It may cause radio frequency interference. The **DENT PULLER** has been designed to be used by an operator using the foreseen control devices.

NOTE: All modifications, even slight ones, are forbidden. They will invalidate the **DENT PULLER EC** certification and its warranty.

OUR COMPANY is not responsible for any damage to people, animals, things and to the **AUTO MIG** itself caused by either a wrong use or the lack or the superficial observance of the safety warnings stated on this manual, nor is it responsible for damages coming from even slight tampering or the use of not-suitable spare parts, or of spare parts other than the original ones. The specification is subject to change without notice.

IMPORTANT: BEFORE STARTING THE EQUIPMENT READ THE CONTENTS OF THIS MANUAL, WHICH MUST BE STORED IN A PLACE FAMILIAR TO ALL USERS FOR THE ENTIRE OPERATIVE LIFE-SPAN OF THE MACHINE THIS EQUIPMENT MUST BE USED SOLELY FOR DENT REMOVAL OPERATIONS.

2. Safety Precautions

When operating this machine, follow basic precautions, including the following:



Warning / Note: It is used to alert you to potential personal injury hazards. Obey all safety messages that follow this symbol to avoid possible injury or death. Addresses practices not related to personal injury. Use this equipment only for its intended use.



Use of Gloves: The person must wear safety gloves. Avoid wearing rings, metal watches and clothes with either metal accessories or components.



Use of Goggles: The person must wear safety glasses or goggles. Make sure to use safety goggles when denting. Otherwise, the sparks might injure the eyes.



Electrical Hazards: All electrical connections must be made by a qualified electrician. Risk for electrical shock.



Thermal Warning: Do not touch the connectors or electrodes during or immediately after use.



Use of Boiler Suits: The person must wear a safety suit for avoiding sparks from the operation.



Use of Safety Shoes: The person must wear a safety shoe for avoiding sparks from the operation.



Read Manual: Read all instructions before using this machine and its attachments.



Pacemaker: Notice that this type of machine generates strong magnetic fields attracting metals and damage watches, magnetic cards and magnetic data storage media. Since these magnetic fields can affect pacemakers, the wearers must consult their doctor before approaching the weld area.



Protect the operator from possible spatters of melted material. Keep the **DENT PULLER** near the working area free from flammable materials. In case the material to be welded produces either smoke or fumes, install a proper fume extractor.



In addition to the information stated in this paragraph, always operate under all the relevant laws in force.



SAFETY MEASURES NOTES:

- Before using the machine, always check the cable and the plug. If any problems are noticed, do not operate the machine.
- Always consult a technician to identify or repair any faults in the machine. Do not attempt to fix it on your own.
- Before executing any repair works on the machine, make sure it is unplugged.
- It is advisable to wear protective goggles, safety shoes and work gloves while using the machine.
- Always remember to unplug the device that is not in use.
- Do not attempt to make any changes to the design of the machine.
- The machine generates strong magnetic fields and might damage clocks, magnetic cards and other carriers.

- People with pacemakers must first seek a physician's opinion before approaching the vicinity of the work environment.
- Before using the device, the user should take extra care to remove jewellery, watches or any clothing that contains a high amount of metal that could heat up by induction.
- Do not touch the stud or worked surface until it cools.
- Do not operate the machine with its protective case removed or touch the grounded surface while operating.



WARNING: Inhalation of toxic gases while operating the machine may cause discomfort or sickness

3. Technical Data

Description	XMD 01
Input Voltage and Frequency	230 V / 50 Hz
Output Voltage and Frequency	7 V / 50 Hz
Rated power at 50%	10 kVA
Output Cable (+ve)	50 mm ² x 2 M
Output Cable (-ve)	50 mm ² x 2 M
Input Cable	2.5 mm ² x 3 core x 2 M
Protection class	IP 21
Dimensions and Weight	650mm x 425mm x 900mm
	37 kg
Maximum weld time	460 ms
Duty Cycle	80%
Fuses	250 mA x 38mm - Glass type

4. Electrical Installation

First, check that the machine is of the right class in comparison with the working environment. This must be carried out by skilled personnel. All connections must be carried out by current regulations and in full observance of safety laws. The machine should be kept on the trolley.



Extension cords of up to 30m must have a cross-section of at least 2.5 mm²

- Arrange the machine in the proper setup as the machine should be kept at a clean surface.
- The device must be installed on public mains at high voltages meant for domestic buildings as it may cause electromagnetic interference and avoid the use of extension boards.
- Use a supply socket (16 Amps) and MCB with a rating of 32 Amps. If the workplace is available with ELCB that should be not below 40 Amps and 30 mA.
- Before the main connection check the power remains off and the power is low.
- Place the machine on the levelled floor to keep the machine out of rolling.



The resistance welding equipment is not intended to be used on a low-voltage public network that supplies domestic premises. It may cause radio frequency interference. Installation must be carried out by specialized personnel, aware of all safety rules. This unit can be supplied for different power supply versions. Before connecting the unit to the power line, check if the voltage shown on the features plate corresponds to the one of your power supply.

Refer to the "**Technical Data**" table to determine the cables section to be used, according to their length. **Fuses** must be delayed-type. To facilitate the maintenance operation, we recommend you to a cut-off electrical supply to the **DENT PULLER** machine using the disconnecting mains switch.

5. Ideal Working Conditions

The device is to be used for the sole purpose of removing dents and shrinking. Using the machine for other purposes is not advised and may cause it to malfunction.

- Stable line voltage of 230V.
- 2 kVA on-load capacitor serial to the incoming line.
- The fusing elements should be strong and not to be loosely connected.
- Extension cable must be short in length and 2.5 sq.mm in size.
- The weld area should be clean and out of oil, dirt etc.
- Use proper tools for right welding.



NOTE: The dent puller must be installed in an area fulfilling the following conditions.

- Under a covered roof.
- Proper ventilation.
- Free from dust.
- Steam/Chemical fumes free.
- Good lighting.

- Normal humidity (Below 98).
- Temperature 0-55 degree Celsius.
- Free from inflammable materials.
- Good ground level.

6. Control Panel

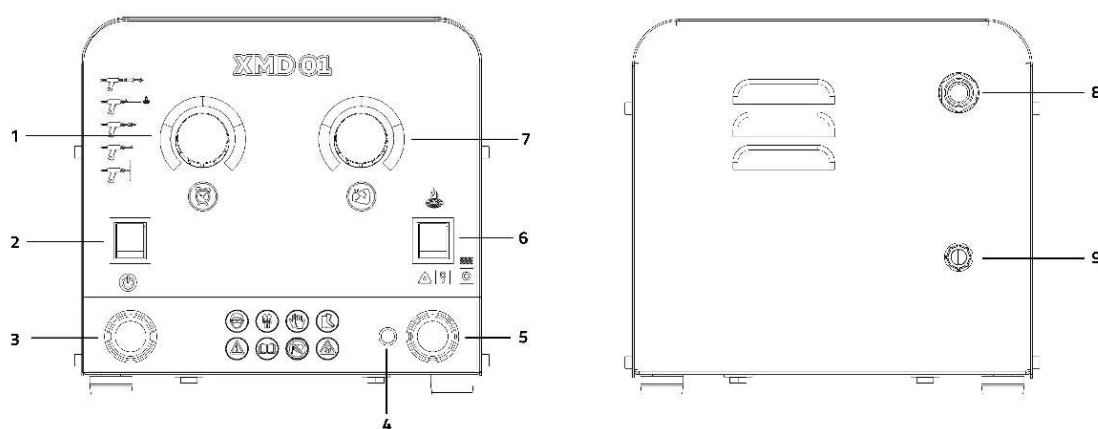

#	Item	Description
1	Time Regulator Knob	This knob helps the operator to adjust the time from 0 to 100%.
2	Rocker Switch for Power On/ Off	This switch can be used to power on/off the machine.
3	Negative Cable Output	This Negative Cable comes from the machine that should be connected to the body or metal panel that is to be operated.
4	Trigger Gland	This cable is directly connected to the Gun which enables the operator to give the trigger.
5	Positive Cable Output	This cable is directly connected to the Gun which enables the operator to do the necessary work.
6	Rocker Switch Operation Selector	By placing this switch upwards the operator can select Shrink Mode and by placing it downwards the operator can select Dent Mode.
7	Power Regulator Knob	This knob helps the operator to adjust the power from 0 to 100%.
8	Gland	This section carries the input cable and protects the cable from wear and tear.
9	Fuse Holder	The delayed fuse of 250mA protects the machine from overload or power fluctuations.

7. Description of Working Cycle

MODE: DENT/SHRINK

Dent mode is the mode that helps the operator to repair the damaged part of the automobile panel using the sliding hammer or appropriate tools and accessories.

Shrink mode is the mode that helps the operator to shrink the panel using the carbon rod or copper rod and can adjust the temperature using the power.

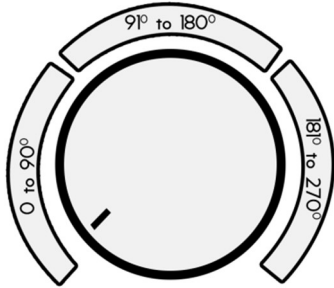

KNOB: It is a rotary switch used to control the ADC value. The following image shows the different positions of the switch and its corresponding value.

- 0 to 90 degree (green zone) - Recommended working condition
- 91 to 180 degree (white zone) - For thick panels
- 181 to 270 degree (red zone) - Extreme conditions

ADC Value: Analog-to-digital converters, abbreviated as "ADCs," work to convert analog (continuous, infinitely variable) signals to digital (discrete-time, discrete-amplitude) signals. In more practical terms, an ADC converts an analog input, such as a microphone collecting sound, into a digital signal

POWER: It is a representation of machine output. The power of a machine is defined as its rate of doing work. It is the rate of transfer of energy. The power of a machine is said to be one watt if it can work at the rate of one joule in one second.

TIME: The measured or measurable period during which an action, process, or condition exists or continues.

The following image shows the output concerning the different knob positions.

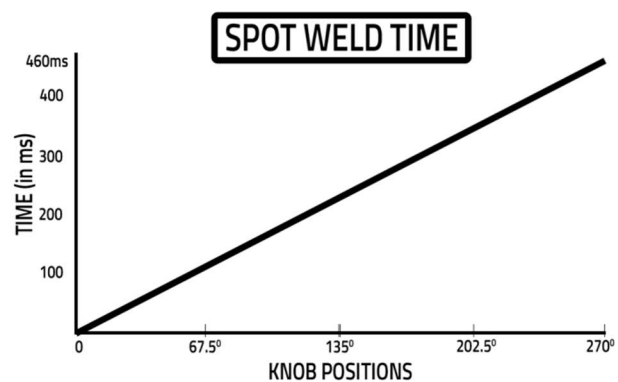
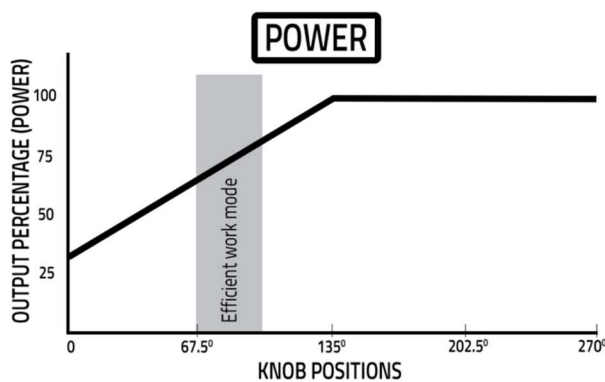

8. Use of Tools

Panel repair with dent puller is a repair method where a round/long/twisted washer or triangle tip is welded to a low spot of a panel. This washer is then pulled outwards so the dent is repaired. Since this method is performed on the outer surfaces, it is ideal for repairing damage on outer areas inaccessible from the inner side.

A dent puller is a type of electrical resistance welder. A washer/tip that is held by an electrode will come in contact with the sheet metal. A large current is then applied to this area, and the heat that is created by electric resistance will weld the contact area.

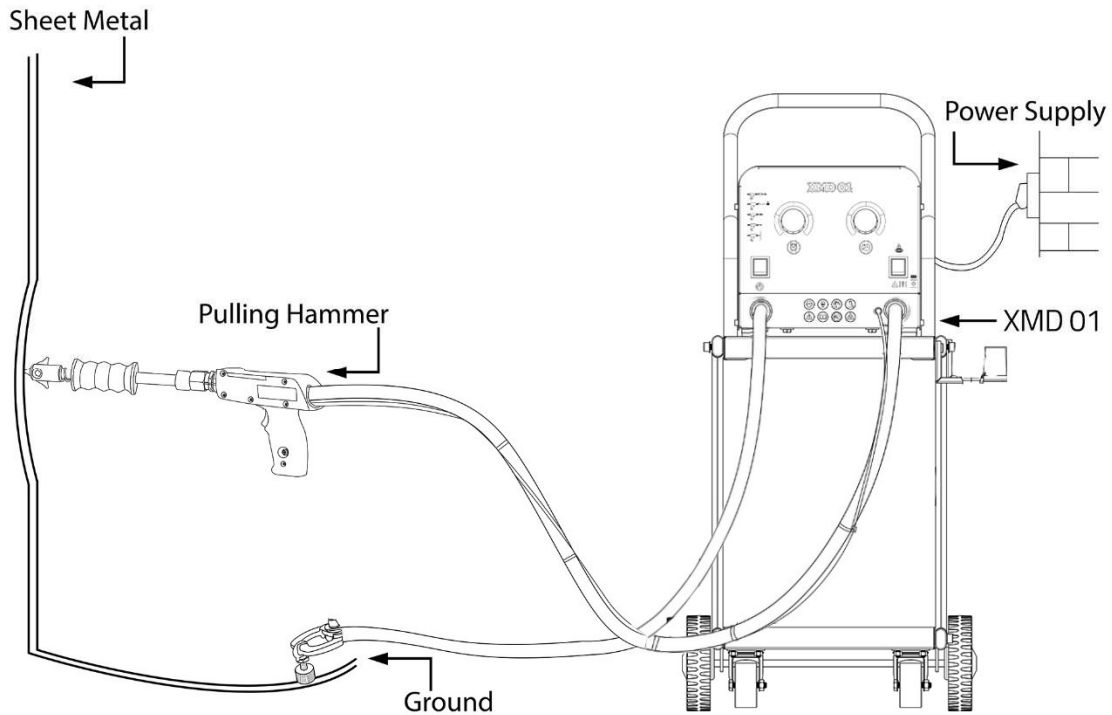

In the circuit shown above, the area in which electric resistance is greatest is where the washer/tip and the sheet metal come in contact with each other. When the electrical current passes through an area with large resistance, the electrical power will be consumed in that area, where heat is generated.

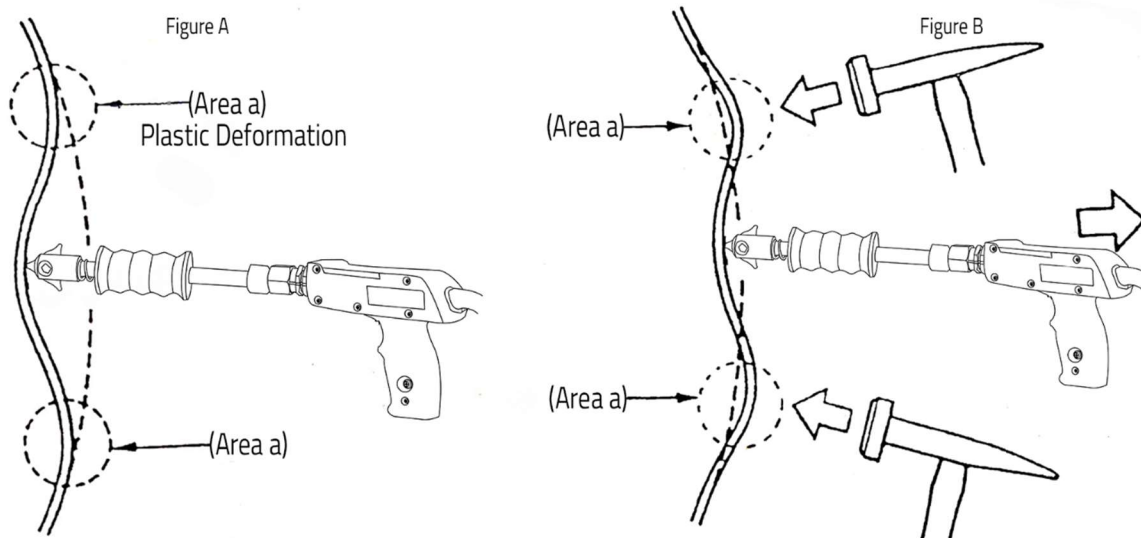

From the figure on the top, the technique of correcting a panel deformed welding a washer or tip onto the panel, uses the identical principle used in the off-dolly technique, where a hammer and dolly are used. In the case of the off-dolly technique, a dolly is placed on the low point of the dent on

the inside of the panel. However, in the case of the dent pulling technique, a washer or tip is welded onto the outer surface of the panel, and instead of pressing the dolly outward, the washer is pulled out from the outer surface.

As shown in figure b, as the washer or tip is pulled outward, the plastic deformation areas (areas a) located at the periphery of the dent, will begin to protrude. These areas should then be hammered down to correct the dent area on which the washer or tip was welded. When this method of pulling on the washer or tip is used to repair panels, small dents will remain. These small dents have to be filled with putty.

Step 1: Assessing the extent of the damage

Assessing visually

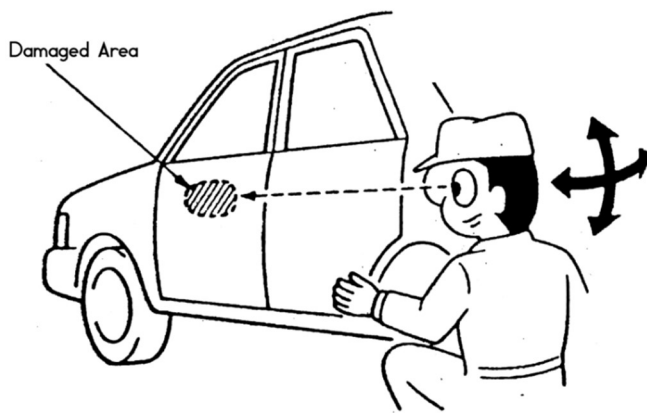

Examine the reflection of fluorescent light on the panel to assess the extent of the damage and deformation level. It is important to inspect the damaged area and its surrounding parts at this stage because it will be difficult to make an accurate assessment of the damage once a repair has started. If repair is started at this point, the painted surface may be affected.

Note: move your viewing angle while assessing the damaged area and bring your line of sight to the level of the area.

Step 2: Clean the panel

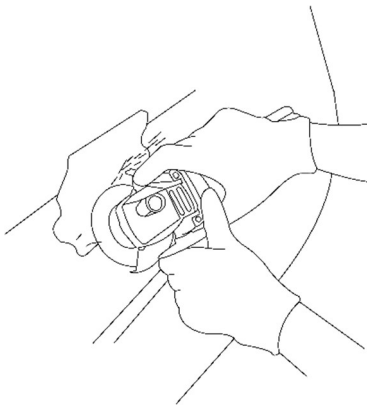

Clean the dent area, remove the paint from the dented area using a single action sander with 60 grit size paper. And also use the sandpaper wheel to remove the paint where we want to fix the earth clamp.

Step 3: Fix the Earth Bolt

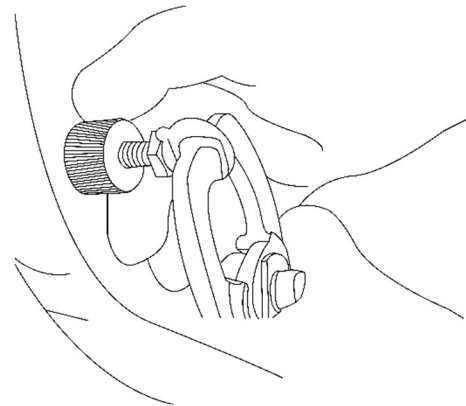

Make a secure connection of the earth clamp or bolt with the panel.

Step 4: Panel repair methods

Dent pulling using triangle/delta tips

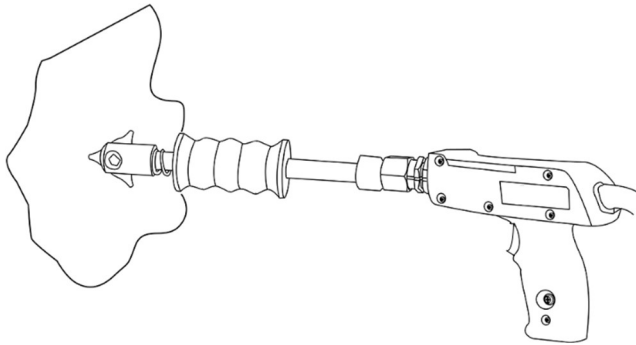

Fix the triangle tip in the sliding hammer, firmly push the electrode tip against the spot to be pulled and push the trigger button (on the pistol grip). Then the machine will pass a huge amount of electricity through our gun and tips, thus causing a weld between the panel and the tip. Afterwards do the hammering by sliding the hammer backwards. To remove the triangle tip, twist in a clockwise direction. Repeat the process until the dent is removed

Dent pulling using round washers

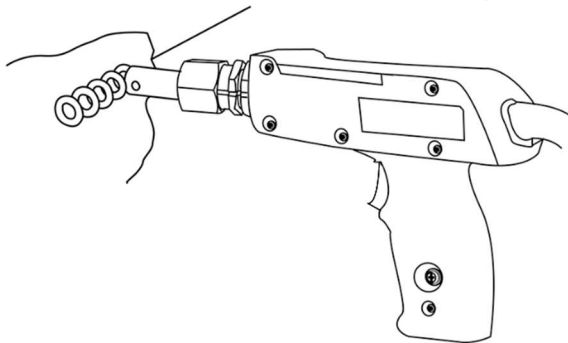

Round Washer welding is a traditional method of dent pulling using specially designed, copper-coated washers. Weld the washer onto the panel at the required points with the help of the washer welding tip and pull out the dents with a claw jaw hammer. Use L rod and Claw Hammer to remove long and deep dents.

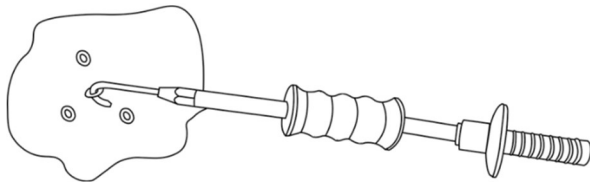

Single round washer pulling method

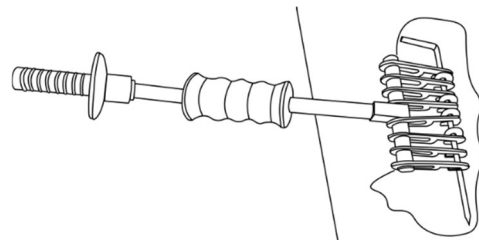

L rod method

Dent pulling using Long washers - Twisted washers

This method helps to remove deep dents from the vehicle panel, running boards etc. Weld the long washers along with the panel at the necessary points with the help of a long washer welding tip and pull out the dent using a claw hammer or body straightener.

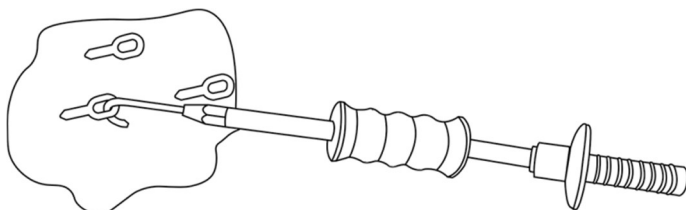

Single long washer pulling method

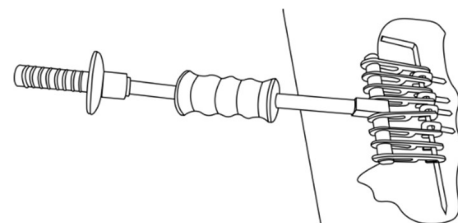

L rod method

Wiggle wire welding

It is a unique method to pull out straight or curved dents. Weld and fix the wiggle Wire with the car body and pull the same with a claw hammer or body straightener. It is usually used in wheel arches, curved press lines etc.

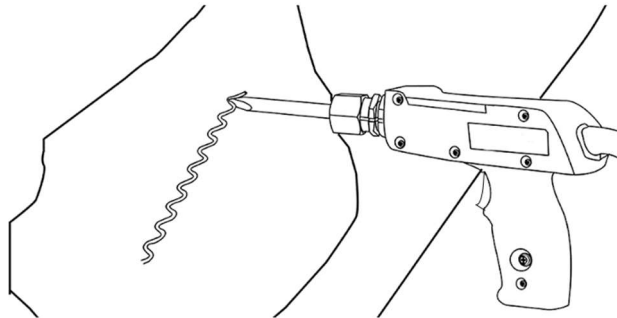

Wiggle Wire Welding

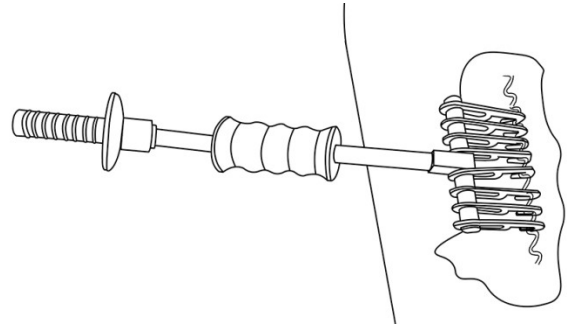

Wiggle Wire Pulling

Step 5: Panel shrinking

After completing the dent removal process, the surface may be over deformed or bulged out to level the surface. Switch the machine into shrink mode using the mode switch. Use the carbon rod or copper rod and adjust power knobs to shrink the surface.

Note: While in shrink mode the power should be adjusted according to the heat required.

Continuous shrinking method (Carbon Electrode)

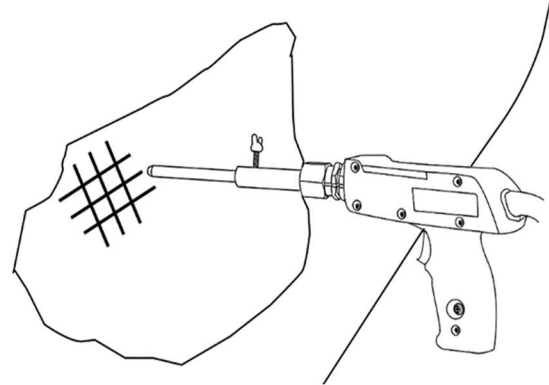
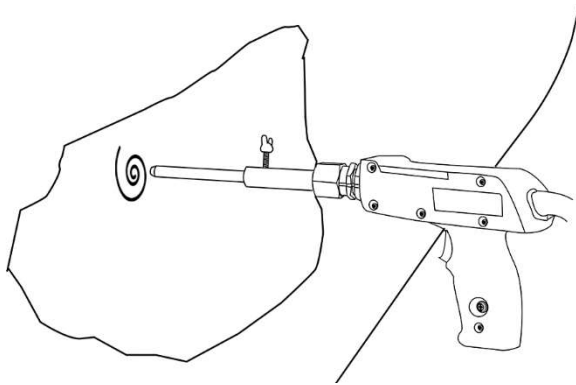

- Shrink the damaged area with a spiralling movement.
- This operation can be used to heat and cool a larger area at the same time.
- Shrink the damaged area with a chessboard shape.
- This operation can be done by moving vertically and horizontally along the line as in the figure.

9. Parts List

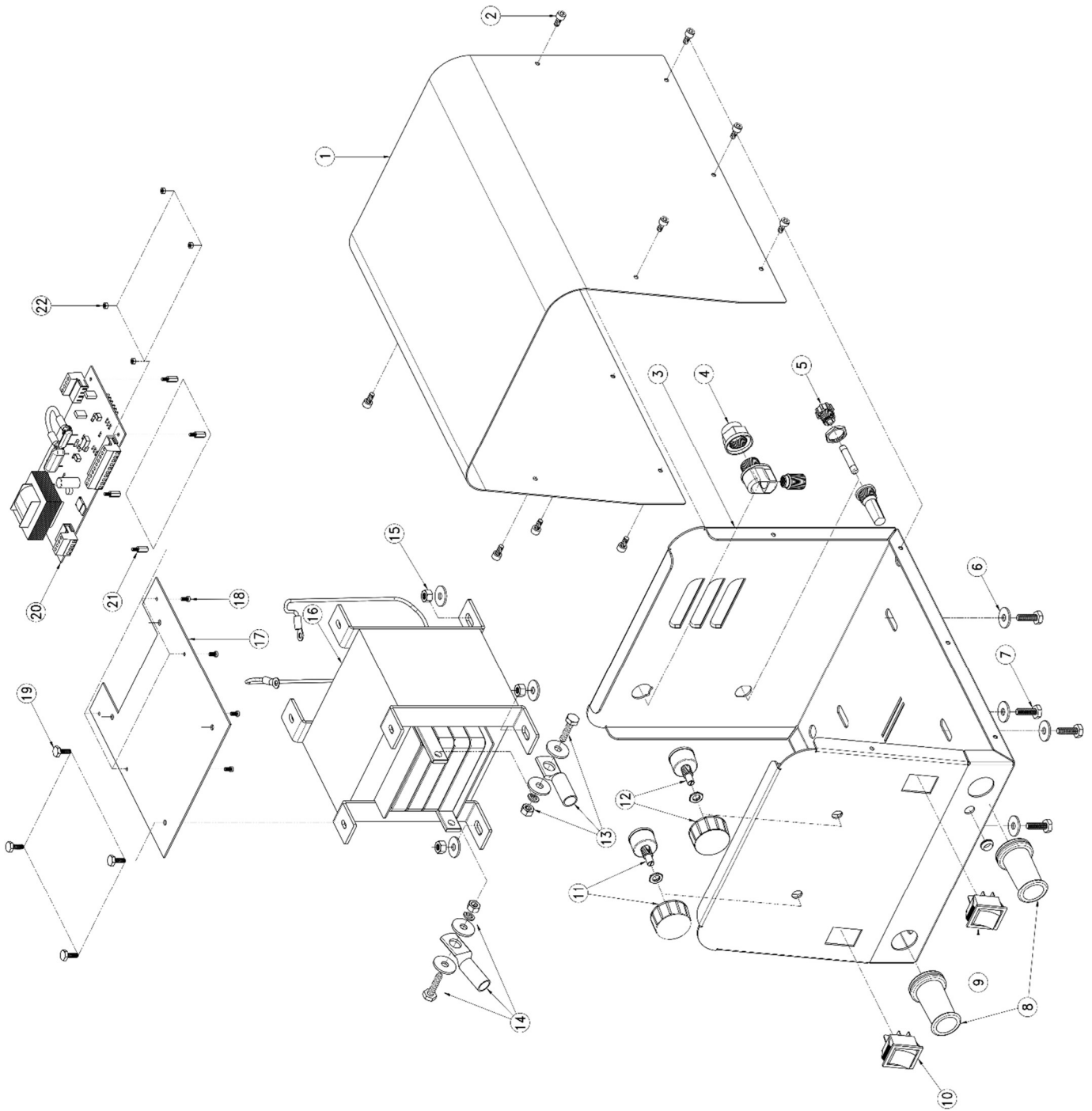

SI No.	Component Description	Quantity
1	Body Top Cover	1
2	Allen Bolts for Top Cover	10
3	Body Bottom	1
4	Cable Gland Assembly for Input Cable	1
5	Glass Fuse and Holder Assembly	1
6	Plate Washers	8
7	Hexagonal Bolt for Transformer	4
8	Cable Sleeves	2
9	Switch for Dent – Shrink Mode Selection	1
10	Power Switch	1
11	Timer Knob	1
12	Output Power Adjustment Knob	1
13	Lug Assembly for Positive Cable	1
14	Lug Assembly for Negative Cable	1
15	Hexagonal Nut for Transformer	4
16	Transformer	1
17	PCB Bracket	1
18	Cheese Head Screws	4
19	Hexagonal Bolts	4
20	Printed Circuit Board (PCB)	1
21	Spacer Screws	4
22	Hexagonal Nuts for PCB	4

10. Wiring Diagram

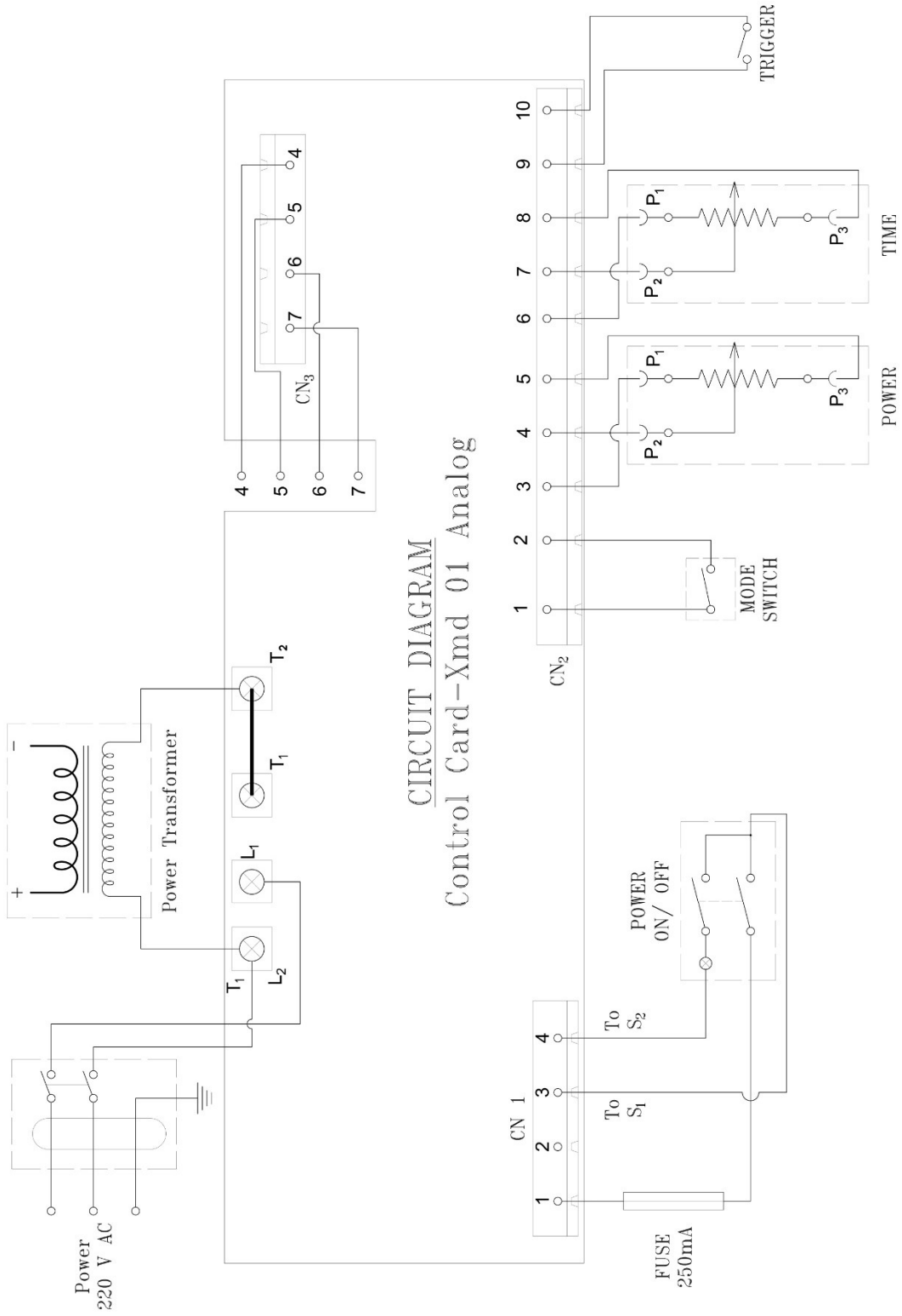

CIRCUIT DIAGRAM
Control Card-Xmd 01 Analog

11. Maintenance and Service

Sl. No.	Symptoms	Causes	Remedy
1	Power Switch not ON	No input or faulty switch	<ol style="list-style-type: none"> 1. Check Power Supply 2. Check Switch
2	Power Switch is ON but not working	<ol style="list-style-type: none"> 1. Faulty Power Switch 2. Fuse is blown off 3. Faulty PCB 4. Faulty Selection Switch 	<ol style="list-style-type: none"> 1. Check Power Supply 2. Check Fuse 3. Replace PCB 4. Check or replace Switch
3	ELCB or MCB falling while machine powered ON	<ol style="list-style-type: none"> 1. Internal electrical short 2. Faulty input connection 	<ol style="list-style-type: none"> 1. Call a technician 2. Check wire of Input Power Supply
4	Too much noise with electrical disturbance	Faulty PCB	Call technician
5	Machine not producing enough Power	<ol style="list-style-type: none"> 1. Too long Input Power cord 2. Very thin input Power cord 3. Very low voltage 4. Broken or loose wire on the Input side 5. Broken or damaged Output cable 6. Earth connection with Work Panel is weak 7. Loose contact in Input and Output Power Side 8. Dusty or Rusty Work area 9. Poor connection with cable and gun cable and sliding hammer brass holder 10. Poor contact between Tip Tightening place 11. Trigger Switch not working 12. Low contact with the panel while triggering 	<ol style="list-style-type: none"> 1. Reduce the length 2. Increase the diameter of the input cable 3. Check voltage 4. Inspect/replace if necessary 5. Inspect/replace if necessary 6. Inspect and rectify earth connection. 7. Check cable and connection 8. Clean work area 9. Check cable and connection 10. Clean the contact area of the TIP and TIP holder 11. Replace the Trigger Switch 12. Educate the operator
6	The machine produces too much vibrant noise	Faulty Electronic Board	Replace the card or contact for Service

7	Machine works unconditionally	Faulty Electronic Board	Replace the card or contact for Service
---	-------------------------------	-------------------------	---

The placing in service of the **DENT PULLER** after an emergency condition must be carried out only by qualified personnel trained to accomplish all the machine necessary tests. After an emergency condition, the machine operations must be restored only by trained personnel capable of carrying out all the machine necessary tests. This chapter states the necessary maintenance operations to be carried out for:

1. Keeping the welding unit safe operating and preserving its efficiency;
2. Avoid the most common causes of malfunctioning and deteriorating quality.

ELECTRICAL CIRCUIT



Electric circuit maintenance must be carried out only by specialized personnel trained to accomplish it under safety conditions.

Disconnect the electric mains before carrying out the following instructions as discharges coming from the supply can be lethal.

- Periodically check ground condition.
- Periodically check the control condition: devices, micro switches, cables, connectors, etc.



In case of emergency, switch off the DENT PULLER using the switch. If there is any water leakage that could enter the DENT PULLER immediately disconnect the electric supply. In case of fire do not use water but proper fire extinguishers.

12. Accessories and Scope of Delivery

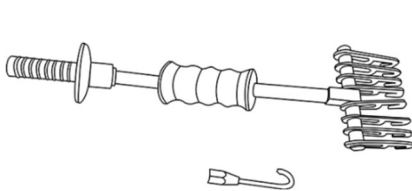

Claw Jaw Hammer – 1 no.

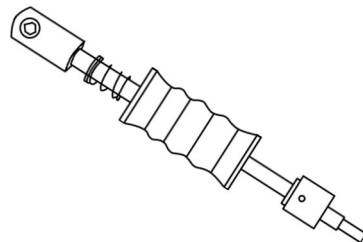

Sliding Hammer – 1 no.

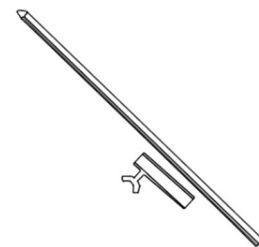

Carbon rod – 5 nos.
Holder – 1 no.

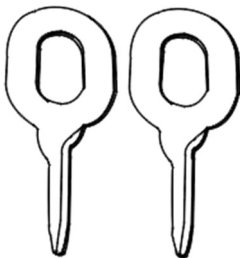

Twisted Washer – 10 nos.

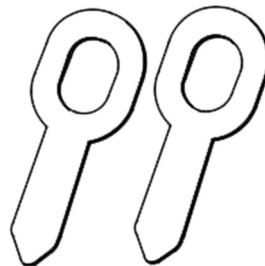

Long Washer – 10 nos.

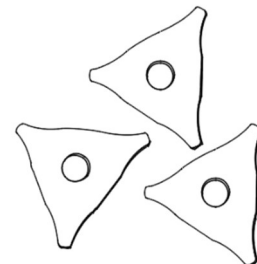

Triangle Tip – 10 nos.

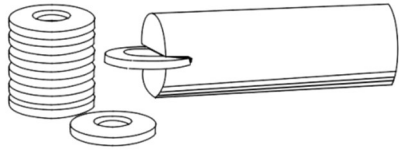

Round Washer Holder – 1 no.

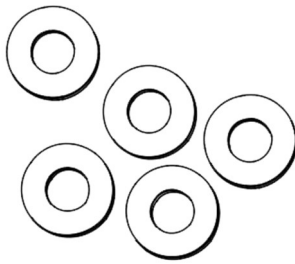

Round Washer – 50 nos.

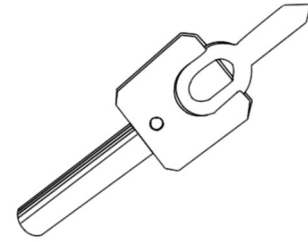

Long Washer Holder – 1 no.

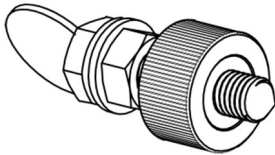

Earth Bolt – 1 no.

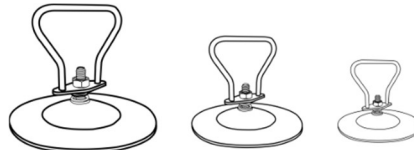

Suction Pad – 1 set

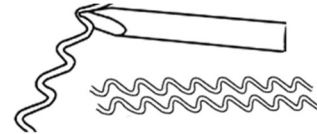

Wiggly Wire – 2 nos.

Holder – 1 no.

13. Warranty Claiming

OUR COMPANY subject to the terms and conditions described below, warrants to its original retail purchaser that new **OUR COMPANY** equipment sold after the effective date of this limited warranty is free of defects in material and workmanship at the time it is shipped by **OUR COMPANY**.

THIS WARRANTY IS EXPRESSLY INSTEAD OF ALL OTHER WARRANTIES, EXPRESS OR IMPLIED, INCLUDING THE WARRANTIES OF MERCHANTABILITY AND FITNESS. OUR COMPANY PRODUCTS ARE INTENDED FOR PURCHASE AND USE BY COMMERCIAL/INDUSTRIAL USERS AND PERSONS TRAINED AND EXPERIENCED IN THE USE AND MAINTENANCE OF THE EQUIPMENT.

OUR COMPANY honour valid warranty claims on warranted equipment for **ONE YEAR** in the event of such a failure within the warranty period. All warranty periods start on the delivery date of the equipment to the original end-user purchaser, and not to exceed one year after the equipment is shipped to a distributor or retail customer. Within the applicable warranty period, **OUR COMPANY** will repair or replace any warranted parts or components that fail due to such defects in material or workmanship. **OUR COMPANY** must be notified in writing within thirty (30) days of such defect or failure, at which time **OUR COMPANY** will provide instructions on the warranty claim procedures to be followed.

OUR COMPANY's Limited Warranty shall **NOT** apply to:

1. Consumable components or parts that fail due to normal wear.
2. Items furnished by **OUR COMPANY** but manufactured by others. These items are covered by the manufacturer's warranty if any.

3. Equipment that has been modified by any party other than **OUR COMPANY**, or equipment that has been improperly installed, improperly operated or misused based upon industry standards, or equipment which has not had reasonable and necessary maintenance, or equipment which has been used for operation outside of the specifications for the equipment.

In the event of a warranty claim covered by this warranty, the exclusive remedies shall be, at **OUR COMPANY**'s option:

1. Repair,
2. Replacement,
3. The reasonable cost of repair or replacement by an authorized **OUR COMPANY** service representative (where authorized in writing by **OUR COMPANY** in appropriate cases), or
4. Payment of or credit for the purchase price (less reasonable depreciation based upon actual use) upon return of the goods at customer's risk and expense. **OUR COMPANY**'s option of repair or replacement will be F.O.B., Factory, or F.O.B. at an **OUR COMPANY**'s authorized service representative as determined by **OUR COMPANY**. Therefore no compensation or reimbursement for transportation costs of any kind will be allowed.

This Limited Warranty provides specific legal rights, and other rights may be available but may vary from province to province.

TO THE EXTENT PERMITTED BY LAW, THE REMEDIES PROVIDED HEREIN ARE THE SOLE AND EXCLUSIVE REMEDIES. IN NO EVENT SHALL MM BE LIABLE FOR DIRECT, INDIRECT, SPECIAL, INCIDENTAL OR CONSEQUENTIAL DAMAGES (INCLUDING LOSS OF PROFIT), WHETHER BASED ON CONTRACT, TORT OR ANY OTHER LEGAL THEORY.

ANY EXPRESS WARRANTY NOT PROVIDED HEREIN AND ANY IMPLIED WARRANTY, GUARANTY OR REPRESENTATION AS TO PERFORMANCE, AND ANY REMEDY FOR BREACH OF CONTRACT TORT OR ANY OTHER LEGAL THEORY WHICH, BUT FOR THIS PROVISION, MIGHT ARISE BY IMPLICATION, OPERATION OF LAW, CUSTOM OF TRADE OR COURSE OF DEALING, INCLUDING ANY IMPLIED WARRANTY OF MERCHANTABILITY OR FITNESS FOR PARTICULAR PURPOSE, CONCERNING ANY AND ALL EQUIPMENT FURNISHED BY OUR COMPANY IS EXCLUDED AND DISCLAIMED BY OUR COMPANY.

14. Test Report

Serial Number	:		
Input Voltage	:		V
Input Current	:		A
Output Voltage	:		V
Output Current	:		A

Date of Test :

Signature :

Remarks :

COMPANY DETAILS OR OTHER INSTRUCTIONS